

GAS GEAR





PLATINUM SERIES

Oxy Kits

- Heavy duty Platinum series cutting, welding and brazing kits
- 7 year warranty offer on regulators, blowpipe handle and cutting attachment
- Bonus combination circle/roller guide
- Robust stainless steel tool box with plenty of space

KIT CONTAINS:

Oxygen Regulator, Acetylene/LPG Regulator, Blowpipe Handle, Cutting Attachment, Brazing Mixer, 3 Brazing Tips, 3 Cutting Tips, 10m Hose Set, Tip Cleaners, Flint Lighter, Combination Circle/Roller Guide, Shade 5 Oxy Specs, Multipurpose Spanner, Set of 4 Flashback Arrestors.



Part No.	Description
4-OXACK	Oxy/Acetylene
4-OXLPG	Oxy/LPG

PLATINUM SERIES

Gas Regulators



Quality without shortcuts

Designed and manufactured by a team with over 40 years' experience in gas equipment engineering.

Peace of mind

Proven reliability. Complies with AS4267. Individually QC Tested. Date stamped for periodic testing in accordance with AS4839.

One-piece encapsulated seat with sintered filter

Superior performance & reliability vs traditional seat designs. Smoother & more consistent flow/pressure delivery. Improves weld quality and reduces troubleshooting issues exacerbated by inconsistent gas delivery.



Internal pressure relief safety valve*

Protects from overpressure hazard. Built into regulator body to protect from contamination, damage & tampering, and ensure reliable operation.

*Applies to Oxygen & Argon/CO2 models only.





PLATINUM SERIES

Gas Regulators - Cont'd

MIG/TIG Welding Series (Shielding Gases)

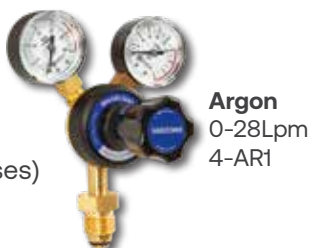

Argon
0-28Lpm
4-AR1



Argon w/ Flowmeter
0-15Lpm 4-ABFR15
0-25Lpm 4-ABFR25
Flowmeter Only
0-15Lpm 4-BF15
0-25Lpm 4-BF25



CO2
0-28Lpm
4-CO2R1

Oxy/Fuel Series



Oxygen
0-1,000 kpa
4-OXR1



Acetylene
0-150 kpa
4-ACR1



LPG
0-300 kpa
4-LPR1

Nitrogen Series



Nitrogen
0-5,000 kpa
WC-03401



Nitrogen EHP
0-28,000 kpa
WC-03400

Specifications

Part No	Gas	Type	Max Inlet	Max Output	Inlet Connection (Per AS2473)	Outlet Connection (Male)
4-OXR1	Oxygen	Twin-Gauge	30,000 Kpa	1,000 Kpa	Type 10.5	5/8" UNF RH
4-ACR1	Acetylene	Twin-Gauge	4,000 Kpa	150 Kpa	Type 20	5/8" UNF LH
4-LPR1	LPG	Single-Gauge	2,500 Kpa	300 Kpa	Type 21	5/8" UNF LH
4-AR1	Argon	Twin-Gauge	30,000 Kpa	28L/min	Type 10	5/8" UNF RH
4-ABFR15	Argon	With Bobbin Flowmeter	30,000 Kpa	15L/min	Type 10	5/8" UNF RH
4-ABFR25				25L/min		
4-BF15	Argon	Flowmeter Only	-	15L/min	5/8" UNF RH	5/8" UNF RH
4-BF25				25L/min		
4-CO2R1	CO2	Twin-Gauge	30,000 Kpa	28L/min	Type 30	5/8" UNF RH
WC-03401	Nitrogen	Twin-Gauge	22,000 Kpa 220 bar 3,190 psi	5,000 Kpa 700 psi	Type 50	7/16" JIC RH
WC-03400	Nitrogen	Twin-Gauge, Piston Sensing	40,000Kpa 400 bar 5,800psi	28,000 Kpa 280 Bar 4,000 psi	Type 50 & Type 51	7/16" JIC RH

FLASHBACK ARRESTORS

Medium Flow Rated

- Conform to AS4603-1999 & EN ISO 5175-1
- Individually flashback, flow & leak tested
- Independently certified
- Thermal cut off valve for protection against sustained flashback (Regulator Models)
- Up to 35% higher flow capacity*
- Suitable for a broad range of applications, including: cutting, gouging, brazing, medium-to-heavy heating**

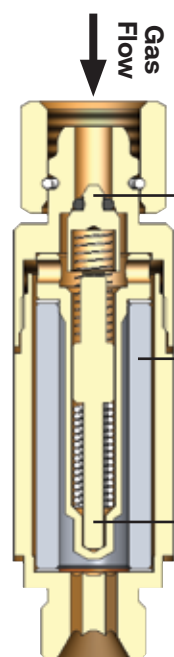

Non-Return Valve
Prevents the passage of gas in the opposite direction to normal gas flow.

Flame Arrestor
A sintered stainless-steel filter (which all gas must pass through) - blocks the flame.

Thermal Cut-Off Valve
(Regulator Models only)
If the arrestor overheats this valve will activate and permanently shut off the flow of gas in any direction. This can occur in the event of repeated or continuous flashback.

Part No.	For	Gas
P4-FBARF2	Regulator	Acetylene / LPG
P4-FBARO2		Oxygen
P4-FBATF	Torch	Acetylene / LPG
P4-FBATO		Oxygen

*Vs some other brands of standard model arrestors. **Max recommended torch/tip oxygen gas consumption of 500L/min. For very heavy heating applications exceeding this, high-flow arrestors are recommended.

QUICK COUPLINGS

For Oxy Gear

- Allows equipment to be quickly and safely dismantled/assembled
- Fast change between hoses and different torches
- Complies with ISO7289 / EN561 Standards
- Automatically shuts off when disconnected
- Use for Oxy, Acetylene, LPG, MIG and TIG gas

Part No.	Description	For	Gas
P4-RQCF	Coupler Set	Regulator	Acetylene / LPG
P4-RQCO	Coupler Set		Oxygen / Argon
P4-TQCF	Coupler Set	Torch	Acetylene / LPG
P4-TQCO	Coupler Set		Oxygen / Argon
P4-TQPF	Pin Only		Acetylene / LPG
P4-TQPO	Pin Only		Oxygen / Argon



Regulator Mount

Torch Mount

BLOWPIPE HANDLE

Platinum Series



- Tried, tested & proven quality
- Dual-Stage valves for quick and precise adjustment from fine work through to heavy cutting and heating
- Superior valve design with tension system to prevent accidental adjustment
- Date-stamped for periodic testing as per AS4839



Part No.	Description
P4-BP	Platinum Series

CUTTING ATTACHMENT

Platinum Series



- Tried, tested & proven quality
- Superior valve design with tension system to prevent accidental adjustment
- Stainless-steel lever
- Date-stamped for periodic testing as per AS4839



Part No.	Description
P4-CA	Platinum Series

OXY CUTTING & GOUGING

Tips & Attachments

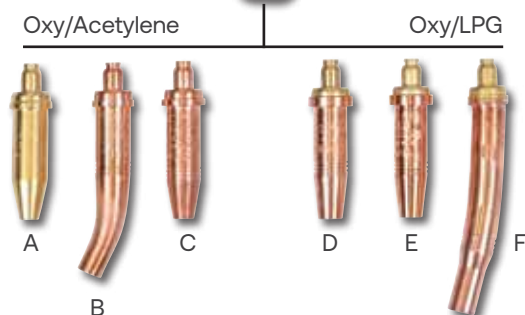

Type	TIPS		Acetylene		LPG		Rec. Approx. Pressure (kpa)	
	Size	Capacity/ Shape	Ref	#	Ref	#	Fuel	Oxy
Cutting	6	1-6mm	A	P4-T416	D	P4-T446	≥ 100	200
	8	6-10mm		P4-T418		P4-T448	≥ 100	200
	12	10-20mm		P4-T4112		P4-T4412	≥ 100	200 - 250
	15	20-75mm		P4-T4115		P4-T4415	≥ 100	350 - 400
Gouging	20	75-125mm		P4-T4120		P4-T4420	≥ 100	400
	32GS	Straight	C	P4-4132GS	E	P4-4432GS	≥ 100	500
	32GB	Bent	B	P4-4132GB	F	P4-4432GB	≥ 100	500
48GB	Bent	P4-4148GB				≥ 100	600	

ROLLER GUIDE

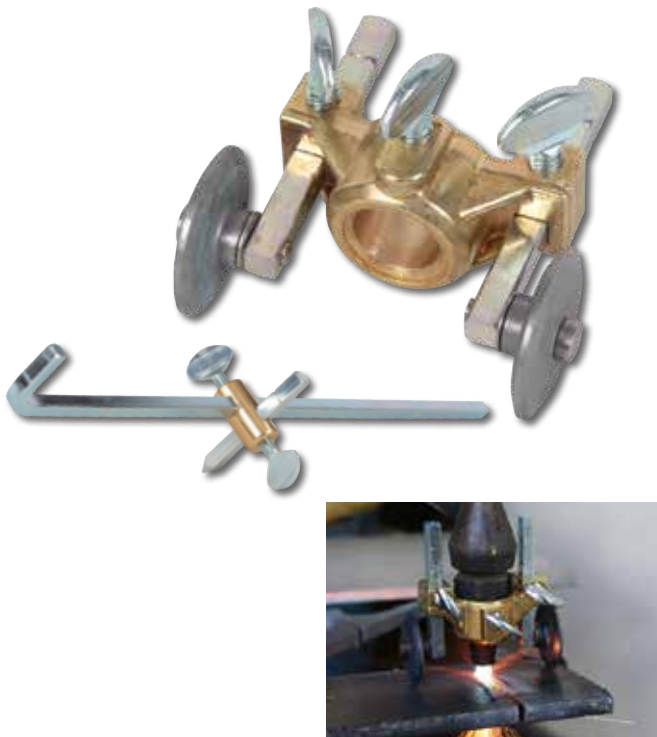

Part No.	Description
P4-TJ1602	Roller Guide Set
P4-TJ6051	Radius Bar - fits TJ4602 Roller Guide to allow circle cutting

CIRCLE GUIDE

- 360 degree cutting from one position
- Height adjustable
- Cuts circles 25-730mm diameter



Part No.	Description
P4-TJ1083	Circle Guide Set
P4-TJ6086	Magnetic Pivot

MACHINE CUTTING

3-Seat Tips

- Suits most straight line & profile cutting machine torches



Oxy/Acetylene
Type 51



Oxy/LPG
Type 54

Size	Steel Thickness	Part No.		Rec. Pressure (kpa)		Cut Speed mm/min
		Acet.	LPG	Oxy	Fuel	
0	<10mm	P4-T510	P4-T540	200	20	660-550
1	10-15mm	P4-T511	P4-T541	280	20	550-490
2	15-30mm	P4-T512	P4-T542	315	20	490-400
3	30-40mm	P4-T513	P4-T543	315	20	400-350
4	40-50mm	P4-T514		315	25	350-320
5	50-100mm	P4-T515		385	35	320-200
6	100-150mm	P4-T516		455	40	200-150

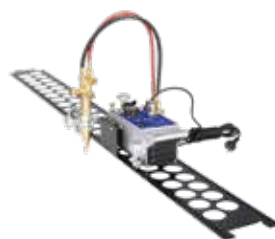

OXY BRAZING

Tips & Attachments

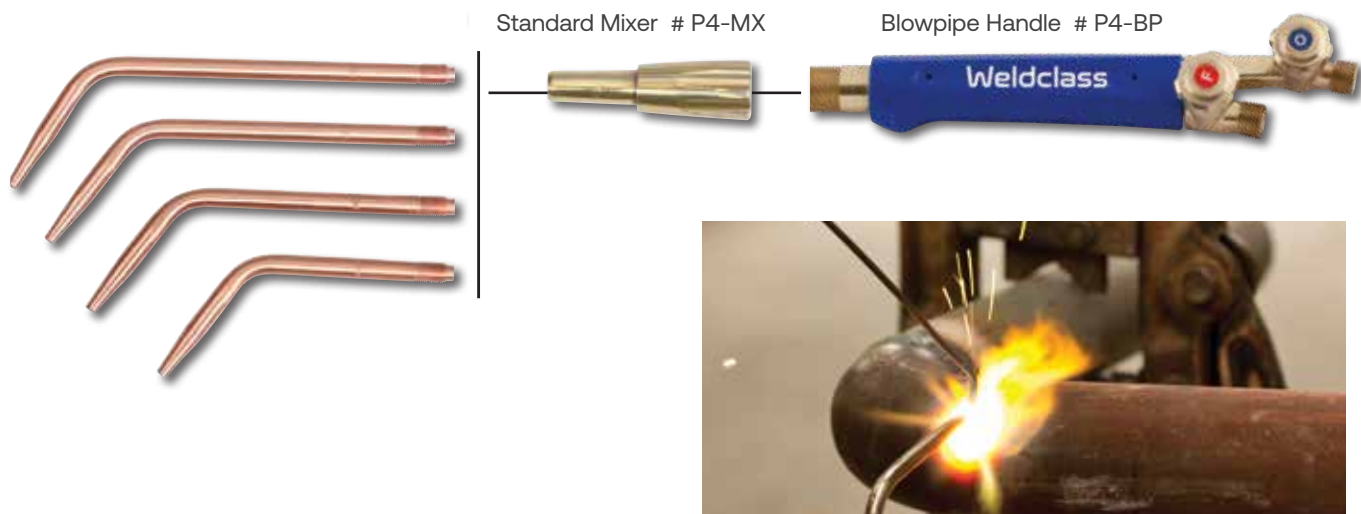

BRAZING TIPS Size	Capacity Max Steel Thickness	Part No.		Rec. Approx. Pressure (kpa)	
		Acet.	LPG	Fuel	Oxy
8	2.0mm	P4-08WT	P4-08WTLP	50	50
10	2.5mm	P4-10WT		50	50
12	4.0mm	P4-12WT	P4-12WTLP	50	50
15	6.5mm	P4-15WT	P4-15WTLP	50	50

OXY HEATING

Tips & Attachments

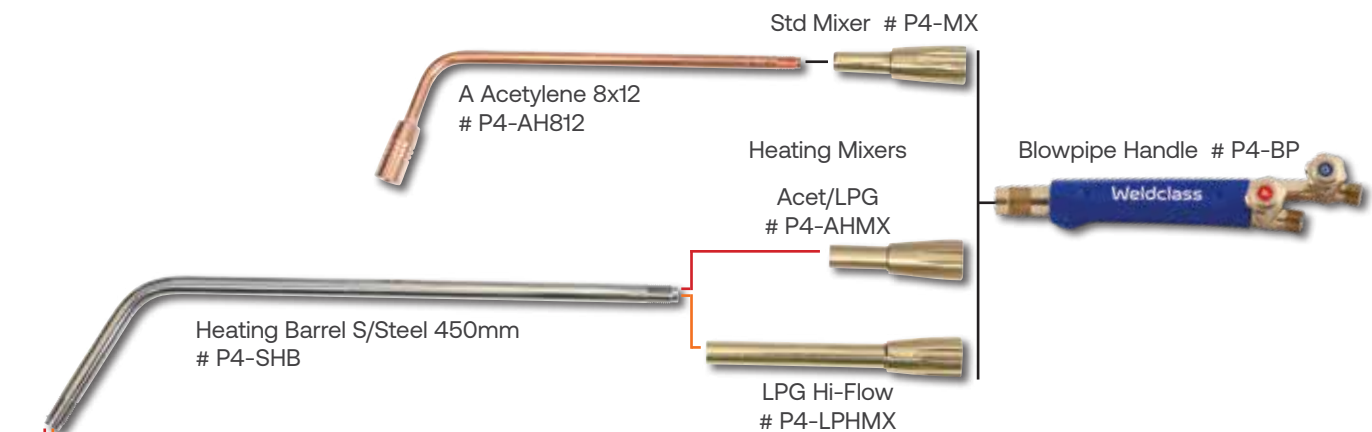

HEATING TIPS					Rec. Approx. Pressure (kpa)	
Fuel Gas	Ref	Size	Max Output	Part No.	Fuel	Oxy
Acet	A	(8x12)	180 Mj/hr	P4-AH812	100	150
Acet	B	1 (8x12)	180 Mj/hr	P4-AHT1	100	150
Acet	C	2 (12x12)	215 Mj/hr	P4-AHT2	100	150
LPG	D	1 (18x12)	280 Mj/hr	P4-LPHT1	100	500
LPG	E	2 (36x12)	420 Mj/hr	P4-LPHT2	100	600
LPG	F	3 (48x12)	560 Mj/hr	P4-LPHT3	100	600
LPG	G	4 (48x15)	840 Mj/hr	P4-LPHT4	300	1,000

PLATINUM LT40 LPG BURNER TORCH

- Air/LPG operation requires LPG gas only (no Oxygen required)
- Robust construction for industrial applications



Impressive Output
Up to 500mj/h (475,000 BTU)
& 1,200mm flame length

Torch Lengths
1,000mm & 600mm

Flame Controls
Heating flame adjustment
Pilot adjustment*
Squeeze trigger*
*(Included on all models, except for Handyflame Kit)

★ **MADE IN EUROPE** ★

7 YEAR WARRANTY OFFER*

Unique Swivel Joint
Eliminates hose torsion/tension

H/Duty Handle
Screwless Single-piece molded design

5/8: UNF
Standard/common connections

Choice of 4 Kits

HANDYFLAME KIT
WC-02988



MAXFLAME KIT
WC-02989



COMBO KIT
WC-02991



TORCH ONLY KIT
WC-02990



Up to 500mj/hr (475,000 BTU) output



Use with standard 4/9/45kg LPG bottle



Metal Heating & Weld Pre-heating



Weed Burning



Bitumen Heating & Concrete Curing



Water-Proofing, Drying & Thawing



Heat Shrinking/ Wrapping



“Very impressed, easy to use, very well made”

- Tony, NSW

PLATINUM LT40 'HANDY FLAME'

Torch Kit

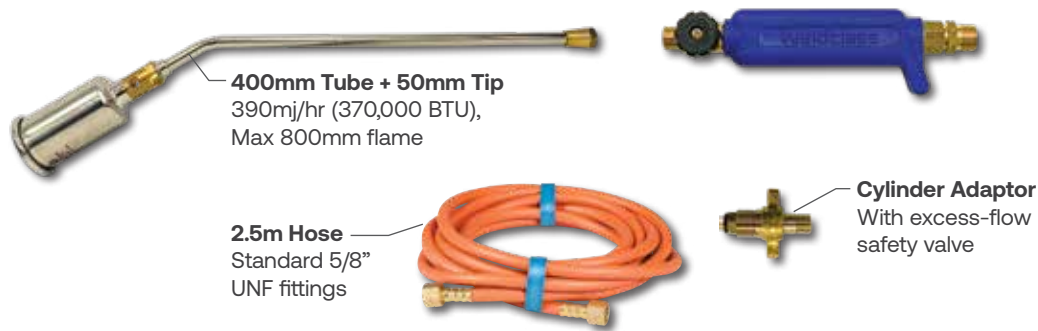

Budget option with good flame power. Operates on full bottle pressure.

Part No.
WC-02988

PLATINUM LT40 'MAXFLAME'

Torch Kit



Operates on full bottle pressure* for maximum heat output & flame size. Includes cylinder adaptor with excess flow safety valve.

*typically 600-1400 kpa depending on ambient temperature

Part No.
WC-02989

PLATINUM LT40 'COMBO'

Torch Kit

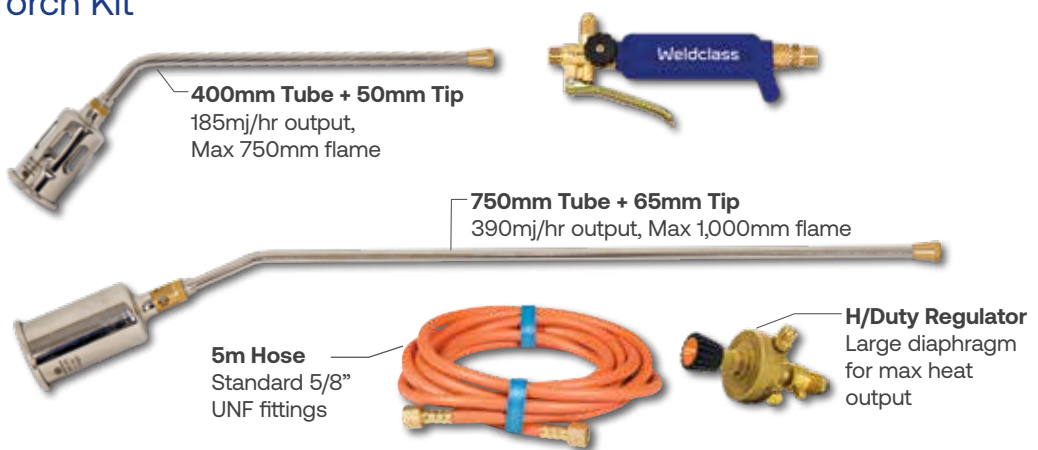

The "all in one" kit with two tube lengths & two tip sizes.

Gas regulator reduces operating pressure to ≤400kpa for reduced gas consumption, more controlled/consistent gas flow & finer flame adjustment.

Part No.
WC-02991

PLATINUM LT40 'TORCH ONLY'

Torch Kit

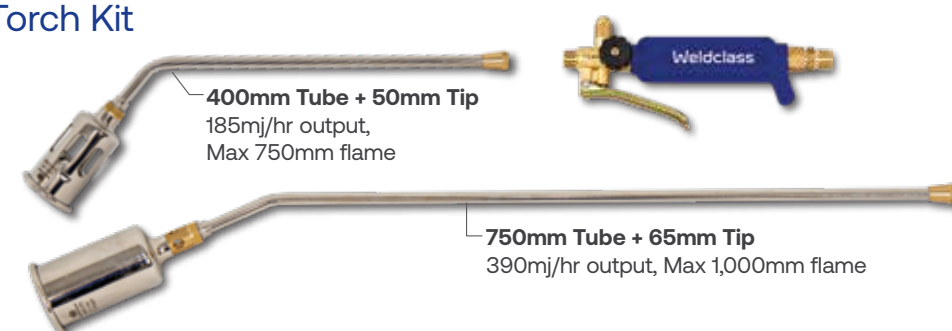

Good choice for fitting to existing hoses & regulator. Includes two tube lengths & two tip sizes.

Part No.
WC-02990

BULK HOSE

- Long life formula
- Ozone resistant and oil resistant
- 5mm I.D.



Part No.	Description	MOQ
4-TWAC5	Oxy/Acetylene (Blue/Red)	100m
4-TWLP5	Oxy/LPG (Blue/Orange)	100m
4-SOX5	Oxygen/Argon/Inert	100m

OXY HOSE SETS

Twin with Fittings

- Long life formula
- Ozone resistant and oil resistant
- 5mm I.D.
- 5/8 UNF Australian standard hose connections



LPG HOSE SETS

Single with Fittings

- Suitable for use with LPG burner/heating torches
- 5/8 UNF LH Connections
- 5mm I.D.



Part No.	Description
4-SLP5M	5m
4-SLP10M	10m

Part No.	Type	Length
4-AC5M	Oxy/Acet (Blue/Red)	5m
4-AC10M		10m
4-AC15M		15m
4-AC20M		20m
4-LP5M	Oxy/LPG (Blue/Orange)	5m
4-LP10M		10m
4-LP15M		15m

MIG/TIG HOSE KITS

For Argon/CO²/ Inert Gases



Ref	Part No.	Description
A	WC-03338	4m with various fittings - Universal kit suits almost any MIG/TIG welder
B	WC-03339	20m with fittings - Cut to desired length & attach fittings as/if required

FLINT LIGHTERS



Part No.	Description
P4-SFL	Single Flint Lighter
P4-SFR	Single Flint Replacements Pk 10
P4-TFL	Triple Flint Lighter
P4-TFR	Triple Flint Replacements Pk 5

TIP CLEANERS

- Abrasive wires remove carbon build up and loose slag from nozzles and tips
- Extra long 125MM tip cleaners are suitable for 3 seat cutting tips



Part No.	Description
P4-TC	Standard 100mm
P4-TCL	Long 125mm

HOSE & GAS FITTINGS

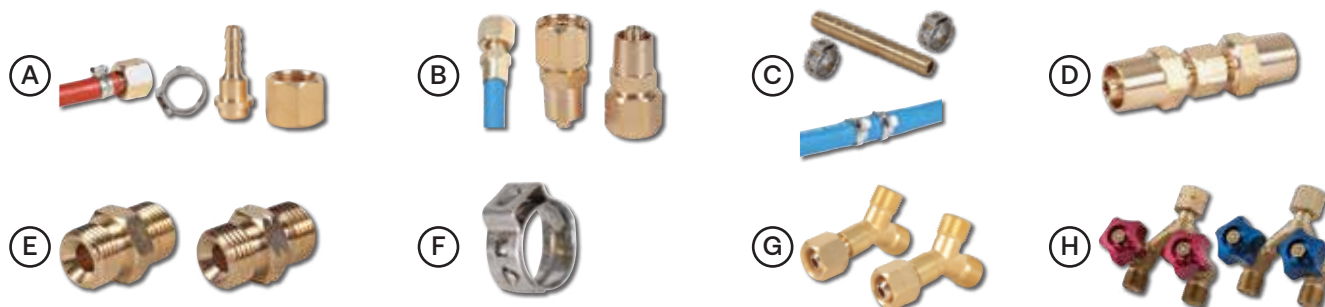

Ref	Part No.	Description	Thread	Gases	Suit Hose Size	Packaging	MOQ
A	P4-RHHCK	Connector Kit Crimp-On	5/8" UNF RH	Oxy/Argon	5mm I.D.	Carded	1
	P4-LHHCK		5/8" UNF LH	Acet/LPG			
	P4-RHHCK10		5/8" UNF RH	Oxy/Argon	10mm I.D.		
	P4-LHHCK10		5/8" UNF LH	Acet/LPG			
B	4-LP112	Connector Screw-On	5/8" UNF RH	Oxy/Argon	5mm I.D.	Bulk	10
	P4-LP112			Acet/LPG		Carded	1
	4-LP240		5/8" UNF LH	Acet/LPG		Bulk	10
	P4-LP240					Carded	1
C	P4-DEBK	Joiner / Double-End Barb Kit	n/a	All	5mm I.D.	Carded	1
	P4-DEBK10						
D	4-LP265	Joiner Screw-On	n/a	All	5mm I.D.	Bulk	10
	P4-LP265					Carded	1
E	4-WB34	Coupler	5/8" UNF RH	All	n/a	Bulk	10
	P4-WB34					Carded	1
	4-WB35		5/8" UNF LH			Bulk	10
	P4-WB35					Carded	1
F	P4-HFC133/10	Hose Clamps	n/a	All	5mm I.D.	Pk10	1
G	P4-R121	Y-Piece	5/8" UNF RH	All	n/a	Carded	1
	P4-R215		5/8" UNF LH				
H	P4-HFYVRH	Y-Piece with Valves	5/8" UNF RH	All	n/a	Carded	1
	P4-HFYVLH		5/8" UNF LH				

LOOKING FOR...

WELDING HELMETS?



Page 19

WELDING BLANKETS?



Page 41

FUME EXTRACTION?



Page 17